

REAR WHEEL AXLE GUIDE

This guide will help you determine if you can attach your trailer out of the box, or if you will require an additional part.

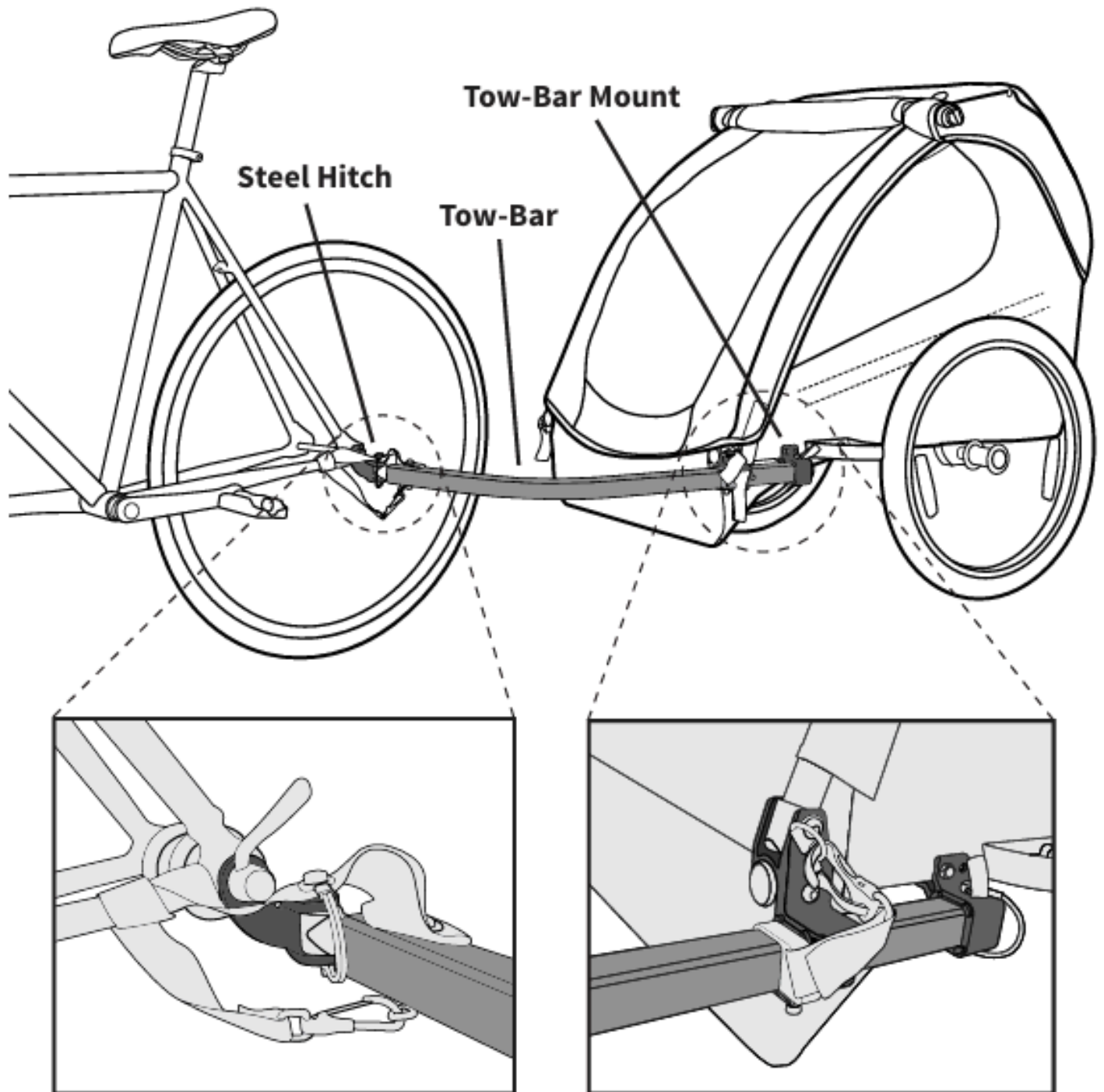

Every Burley trailer comes equipped with a Steel Hitch, Tow-Bar and Tow-Bar Mount. In most cases this is all you will need to safely connect the trailer to your bicycle. In some cases you may require an additional adapter or thru-axle. This guide will help you determine if you require one of these additional parts, and if so, which part you require.

Step 1. Identify Your Axle Type

1

The first step is to identify the type of axle your bike has. There are 3 main types of axles.

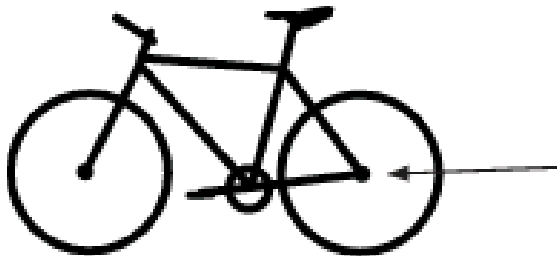

The axle is located here. It goes through the rear wheel of the bicycle.

Quick Release Axle

The most common type of axle. The quick release axle has a lever that clamps the axle in place with an acorn nut on the opposite end.

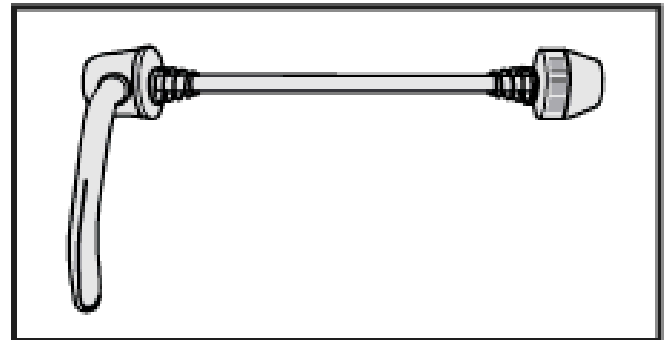

Bolt-on Axle

The Bolt-on Axle has a hex nut on both sides. It is common on fixed gear and single speed bicycles, as well as internally geared hubs.

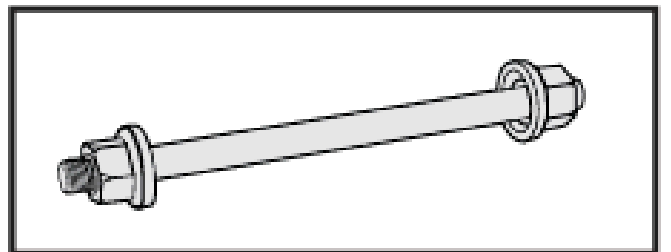

Thru Axle

Thru axles are thick and hollow. They are common on newer bicycles with disc brakes, especially mountain bikes.

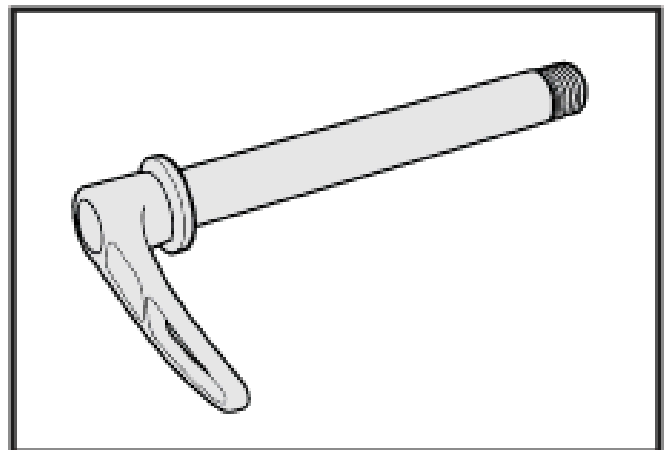

Step 2. Identify Your Dropout Type

- 2 The 2nd step is to determine your dropout type. There are many types of dropouts, but for the purposes of hitching a Burley Trailer, we can group them in to 2 main categories.



The dropouts are located here. They are the two slots that the axle connects to. They hold the rear wheel in place.

Standard Dropout

Most bicycles will have a standard dropout. They won't all look like this, but the key thing to look for is a flat area around and below the axle where the Steel Hitch can sit flush against the frame.

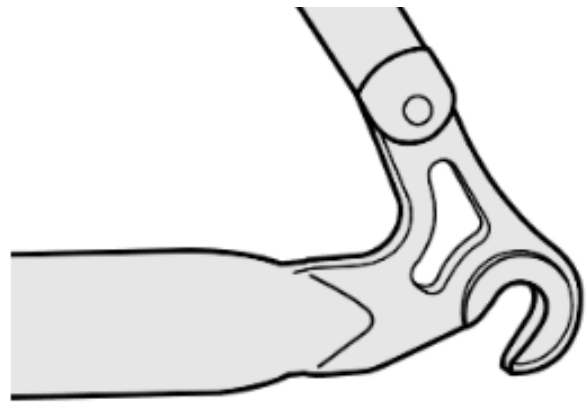

Hooded Dropout

Hooded dropouts have a protruding metal hood that extends around the top of the dropout. They are common on custom or hand-made bikes. They can prevent the Steel Hitch from sitting flush against the frame. This problem is solved by the adapters which you will read about later.

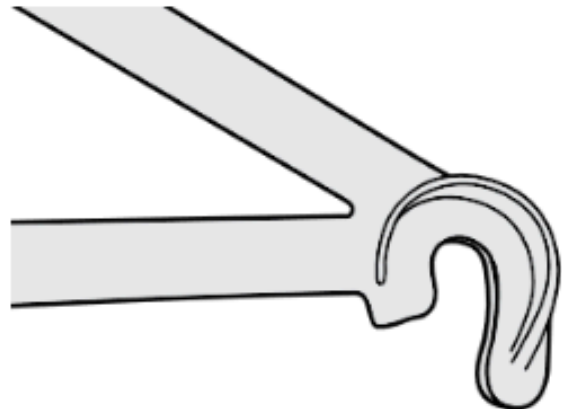

Open Horizontal Dropout

An open horizontal dropout is a rear-facing slot on a bike's frame that allows the rear wheel to slide backward (commonly found on single-speed or track bikes). Burley does not recommend using axle-mounted trailers with these dropouts. The pulling force can cause the axle to shift in the dropout. Movement of the wheel can lead to loss of chain tension, misalignment, and trailer instability. With no fixed stop to hold the axle securely, the connection isn't stable enough for towing. For axle-mounted bike trailers, we recommend using a bike with a vertical dropout.

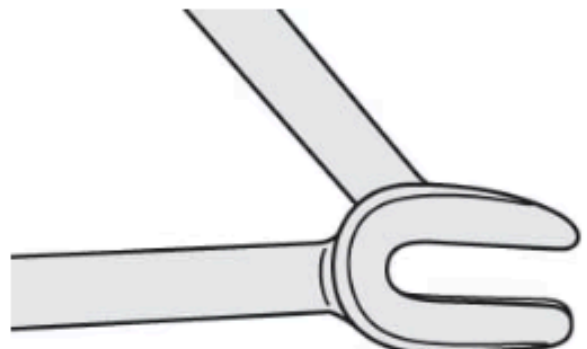

Step 3. Determine if You Need an Adapter

3

Now that you know what type of axle and dropout you have, use the table below to determine if you will need additional parts to connect your Burley trailer.

	Quick Release Axle	Bolt-On Axle	Thru Axle
Standard Dropout	Steel Hitch (Included)	Steel Hitch* (Included)	Steel Hitch (Included) + Burley Thru Axle
Hooded Dropout	Steel Hitch (Included) + Adapter	Steel Hitch (Included) + Adapter	Steel Hitch (Included) + Burley Thru Axle

Most people will have a Standard Dropout paired with a Quick Release, and **will therefore not require any extra parts**. If you **do** require an extra part, keep reading.

Q: What does the adapter do for me?

A: You will need an adapter if your dropout does not have room for the hitch to lay flush against the bike frame, or in some cases if the addition of the hitch makes the axle too short for the nut to be re-installed. In these cases the adapter acts as a spacer. It provides a flat surface away from the dropout that allows the hitch to lay flush to a solid surface. In the case of axles being too short to be reinstalled, it extends the length of the axle so that it can be safely installed with the hitch.

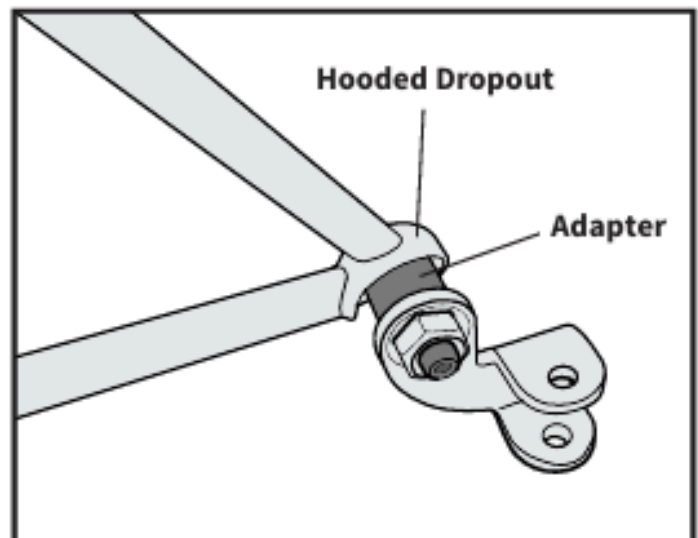

Q: I see there are multiple sizes of Adapters and Thru Axles how do I know which part is right for me?

A: It will depend on the size and threading of your axle. Use the Adapter Guide and Axle Fit Guide on the following pages to determine which part is right for you.

*It is possible that the addition of the standard hitch may make your bolt on axle too short for the nut to be re-installed. If this is the case you will require an adapter.

Step 4. Find Your Adapter

Hitch Adapter

If you need an adapter this guide will help you determine which model is right for you.

There are four adapter models:

QR
3/8 x 26
M10 x 1.0
M10.5 x 1.0

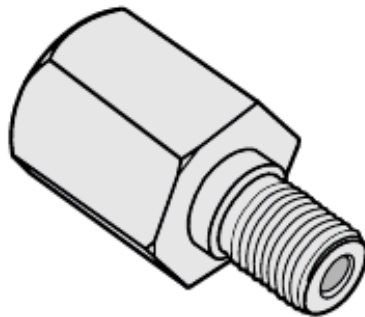

QR (Quick Release) Adapter

If you have a Quick Release Axle you will always go with the QR Adapter. This is the most commonly used adapter.

All Others

The other three models will all apply to bolt-on axles. You must know the Diameter and Thread Pitch of your axle. This information should be acquired from your bicycle/axle/hub manufacturer. Then select the appropriate Adapter according to the axle diameter and thread pitch, which is indicated in the adapters name.

Diameter Pitch

M10 x 1.0

Thru Axle Adapter

Please see next page for the 12mm Thru Axle Fit Guide

Thru Axle Fit Guide

This guide is intended to help determine which Thru Axle you will need for hitching a Burley trailer to your bike.

1

Print this sheet at 100% on 8.5" X 11" paper. Verify the illustration is to scale by using a ruler.



2

Confirm the thread pitch of your current axle by placing it over the illustrations below to find a match. The thread pitch is the distance from the tip of one thread to the tip of the next. If you are unable to confirm the thread pitch using this guide, please contact your bike manufacturer for assistance.

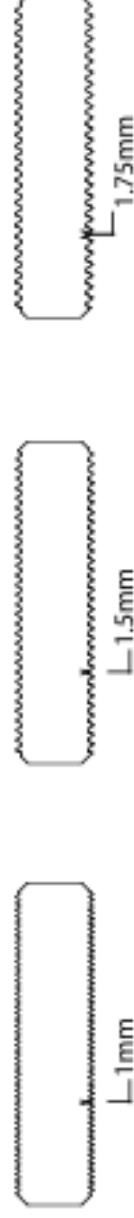

3

Measure the length of your current thru axle using this illustration. Align your axle at 0mm, measure from the base of the axle head to the tip of the threads.



mm 0 10 20 30 40 50 60 70 80 90 100 110 120 130 140 150 160 170 180 190 200 210 220 230

4

Use the thread pitch and axle length to determine which axle you need.

note

If your axle length is not shown for the thread pitch you have, we do not have a compatible thru axle for you at this time.

Thread Pitch (TP)	Frame Measured Axle Length	Compatible Thru Axle	SKU
1.0	~158-174mm	12 X 1.0, 158-174mm	960240
1.0	~167-183mm	12 X 1.0, 167-183mm	960241
1.5	~159-165mm	12 X 1.5, 159-165mm	960242
1.5	~172-178mm	12 X 1.5, 172-178mm	960243
1.5	~229mm	12 X 1.5, 229mm	960244
1.75	~174-180mm	12 X 1.75, 174-180mm	960245
1.75	~229mm	12 X 1.75, 229mm	960246